



2008 DYNA 70'Standard Specification List

ITEM	GENERAL SPECIFICATION
1.	LENGTH OVERALL 21.33M (70')
2.	BEAM 5.50M (18'1")
3.	DRAFT(UNDER PROPELLER) 1.55M(5'1")
4.	HEIGHT ABOVE WATER LINE 4.42M(14' -6")TO TOP OF SCREEN 5.51M(18' -1")TO TOP OF MAST
5.	FUEL CAPACITY 4920 L (1300 U.S GALS)
6.	WATER CAPACITY 946 L (250 U.S GALS)
7.	APPROXIMATE DISPLACEMENT 38000 KGS (83600 LBS)
8.	SLEEPING BERTH 10 ~ 14P
9.	Engine Options: CAT-C18(1000HP) YANMAR-900HP MAN-D2848 LE423(900HP)/D2840 LE423(1100HP)/V12(1224HP)/D2842 LE404(1300HP) /D2842 LE423(1360HP) MTU-8V 2000 M92(1085HP)/8V 2000 M93(1200HP)
10.	ONAN GENERATOR 21.5KW/60HZ (17.5KW/50HZ)
11.	MARINE AIR AIRCONDITIONING THROUGHOUT -TOTAL 88000BTU'S
	HULL FORM AND CONSTRUCTION
1.	DESIGNED BY YANKEE DELTA, MONZA, ITALY
2.	DEEP V FORWARD, SHALLOW V AFTER
3.	ALL FIBERGLASS LAID UP BY HAND
4.	FOAM CORE CONSTRUCTION ABOVE WATER LINE
5.	SOLID FIBERGLASS CONSTRUCTION BELOW WATER LINE
6.	TRANSVERSE AND LONGITUDINAL STRENGTHENING STRINGERS THROUGHOUT HULL
7.	INTERIOR OF HULL BOTTOM PAINTED OUT IN GELCOAT
8.	DECKS SIDES ARE FOAM CORE CONSTRUCTION
9.	HULL AND DECK JOINT BOLTED AND FRP BONDED
10.	MOULDED NON-SLIP DECK SURFACE
11.	ANTIFOULING
12.	LAMINATION WITH VINYLESTER RESIN TO PREVENT OSMOSIS
	DECK FITTINGS
1.	BOW ROLLER & CHAIN LOCKERS W/ 2 HATCHES
2.	RAW WATER ANCHOR WASH DOWN W/ PUMP
3.	REVERSIBLE LOFRANS ELECTRIC ANCHOR WINDLASS
4.	SINGLE STAINLESS STEEL ANCHOR 85LBS WITH 200FT GALVANIZED C HAIN
5.	STAINLESS STEEL CHAINWAY
6.	2 LIFE-RAFT LOCKERS W/ COVERS
7.	STAINLESS STEEL HATCH TO CREW CABIN, 2 HATCHES FOR STB & PORT GUEST CABIN

8.	2 SUN LOUNGE PADS ON FOREDECK
9.	STAINLESS STEEL SPRING CLEATS / SHAFING PLATES
10.	STAINLESS STEEL MOORING CLEATS / SHAFING PLATES
11.	STAINLESS STEEL PULPIT & OVAL GUARD RAILS
12.	RUBBER RUBRAIL WITH STAINLESS STEEL INSERT
13.	WATER & FUEL FILLERS
14.	TEMPERED GLASS DIRECTLY MOULDED ON FRP
15.	DECK LIGHTS & FULL SET NAVIGATION LIGHTS
16.	STAINLESS STEEL OPENING PORTHOLES WITH SCREENS
17.	WATERPROOF SPEAKERS FROM SALOON CD/STEREO SYSTEM
	COCKPIT
1.	ACCESS HATCH TO AFT CABIN
2.	STAINLESS STEEL FRAME SLIDING DOOR TO SALOON
3.	TWIN STAIRS W/HANDRAILS TO FLYBRIDGE AND FORE DECKS
4.	AFT DECK FRP SEAT W/CUSHION
5.	LOCKERS CONTAINING MANUAL BILGE PUMP WITH VALVE CHEST
6.	LOCKERS CONTAINING SHORE POWER INLET
7.	AFT DECK WASH DOWN (FRESH WATER)
8.	SELF DRAINING
9.	COCKPIT HALOGEN LIGHTING
10.	WATERPROOF SOUND MARINE SPEAKERS FROM SALOON CD/STEREO SYSTEM
11.	SAFETY DOOR TO SWIMMING PLATFORM
12.	TRANSOM SHOWER (HOT & COLD)
13.	TRANSOM LAZARETTE WITH STORAGE
14.	STAINLESS STEEL SWIMMING LADDER UNDER COVER
15.	AFT DECK TEAK TABLE
16.	TEAK LAID SWIMMING PLATFORM AND AFT DECK
	FLYBRIDGE AND SECOND HELM POSITION
1.	ACCESSIBLE FROM SIDE DECKS WITH DOORS
2.	SECOND ACCESS WITH WATERTIGHT HATCH FROM SALOON STAIR
3.	STAINLESS STEEL HANDRAIL WITH ACRYLIC WINDSHIELD
4.	HYDRAULIC POWER ASSISTED STEERING SYSTEM
5.	DUAL STATION TELEFLEX MORSE ELECTRONIC ENGINE CONTROLS
6.	UFLEX ITALIAN STEERING WHEEL
7.	START/STOP ENGINES KEYS
8.	AUDIBLE AND VISUAL ENGINE ALARM
9.	ENGINE RPM GAUGES
10.	ENGINE COOLING WATER TEMPERATURE GAUGES
11.	ENGINE OIL PRESSURE GAUGES
12.	RUDDER INDICATOR
13.	BILGE PUMP VISUAL AND AUDIBLE WARNING INDICATORS
14.	BOW THRUSTER CONTROL (15HP)
15.	LOFRANS TITAN WINDLASS CONTROL
16.	GUEST SEARCH LIGHT W/REMOTE CONTROL
17.	MARINE-TYPE AIR HORN W/CONTROL

18.	COMPASS
19.	WATERPROOF INTERCOM
20.	FRP HELM SEATS FOR 4 PERSONS
21.	WET BAR W /ULINE ICE MAKER & FRP LOCKER W/PREWIRED FOR BBQ
22.	LARGE OVAL-SHAPED SEATING WITH CUSHION AND TABLE
23.	TWO HALF-ARCHES AND CENTER RADAR MAST WITH 4 LIGHTS
24.	INTERNATIONAL NAVIGATION LIGHTS
25.	WATERPROOF SOUND MARINE SPEAKERS FROM SALOON CD/STEREO SYSTEM
26.	PRE-WIRING FOR DAVIT
27.	FLAG POLE SOCKET
28.	TRIM TABS AND INDICATORS
	INTERIOR
1.	PLYWOOD FLOOR THROUGHOUT W/ CARPETS
2.	CHOICE OF QUALITY CARPETS, UPHOLSTERY AND CURTAIN FABRICS
3.	HIGH GLOSSY FINISH WITH, TEAK, MAPLE OR CHERRY WOOD VENEER AND CAMPHOR OR MAHOGANY BURL WOOD ON TOPS (OPTIONAL WOOD VENEER AVAILABLE)
4.	SYNTHETIC LEATHER HEADLINERS
5.	DRAPES FOR SALOON WINDOWS
6.	CHOICE OF COLORS FOR ALL INTERIOR GENUINE LEATHER SEATINGS
7.	CANTALUPI CEILING HALOGEN LIGHTS THROUGHOUT
8.	VIMAR SWITCHES AND OUTLETS
9.	GROHE SHOWER FITTINGS
10.	GFI OUTLETS IN CABIN HEADS AND GALLEY AREAS
	MAIN HELM POSITION AND DINETTE
1.	FRP INSTRUMENT CONSOLE WITH BURL PANEL
2.	LEATHER HELM SEAT
3.	REPEAT ENGINE INSTRUMENTS AS UPPER HELM
4.	REPEAT ELECTRONIC ENGINE CONTROLS
5.	REPEAT POWER ASSISTED STEERING SYSTEM
6.	STEERING WHEEL
7.	BOW THRUSTER CONTROL
8.	FUEL LEVEL GAUGES AND RUDDER INDICATORS
9.	ENGINE ROOM FIRE EXTINGUISHER W/ WARNING SYSTEM
10.	COMPASS
11.	INTERCOM
12.	CLEAR FORWARD WINDSCREEN
13.	WINDSCREEN WIPERS W/WATER SPRAY
14.	AC/DC CONTROL PANELS UNDER HELM SEAT
15.	LIGHTS AND SOCKETS
16.	OVAL SHAPED DINETTE LEATHER SETTEE FOR 8 W/ DINING TABLE
17.	ACCESS STAIRS TO LOWER DECK WITH LIGHTED STEPS
18.	OVERHEAD IN SYNTHETIC LEATHER
19.	CEILING HALOGEN LIGHTS

20.	SALOON LADDER TO FLY BRIDGE W/ HANDRAIL
	MAIN SALOON
1.	HALOGEN CEILING LIGHTINGS
2.	DRAPES TO SIDES WINDOWS AND DOORS
3.	OVERHEAD IN SYNTHETIC LEATHER
4.	STYLED MIRROR ON CEILING
5.	FLOOR ACCESS TO ENGINE ROOM
6.	L-SHAPE LEATHER SOFA W/ COFFEE TABLE
7.	CONCEALED TUBE LIGHTING UNDER SOFA AND AROUND OVERHEAD MIRROR
8.	INTERCOM SYSTEM
9.	ACRYLIC MIRRORS INSIDE LIQUOR CABINET
10.	WET BAR AREA WITH ICE MAKER OR FRE EZER
11.	ENTERTAINMENT CABINET
12.	CIRCULAR ACCESS STAIRS DOWN TO AFT CABIN
13.	S.S. FRAME DOOR TO AFT DECK
	GALLEY
1.	TEAK AND HOLLY OR GRANITE/MARBLE FLOOR
2.	KENYON CERAMIC 3-RING HOB
3.	EXHAUST FAN OVER STOVE
4.	FULL HEIGHT REFRIGERATOR
5.	GRANITE OR CORIAN COUNTERTOP
6.	CONVECTION MICROWAVE
7.	DOUBLE SINKS W/ HOT & COLD MIXED FAUCET
8.	TRASH BIN
9.	LOCKERS & DRAWERS
10.	FISHER & PAYKEL DISHWASHER CONNECTED TO FOOD WASTE DISPOSER
11.	POWER SOCKETS
12.	WATER GAUGE AT OVERHEAD CABINET
	FORWARD CREW CABIN
1.	TWIN SINGLE BERTHS W/ MATTRESSES
2.	OPENING HATCH TO FOREDECK WITH STAINLESS STEEL LADDER
3.	HANGING LOCKER WITH LIGHT
4.	RADIO AND SONY CD PLAYER WITH SPEAKERS
5.	WASHROOM W/ ELECTRIC TOILET AND BASIN
6.	SHOWER FAUCET HOT AND COLD
7.	EXHAUST BLOWER
8.	INTERCOM SYSTEM
9.	LIGHTS AND SOCKETS
10.	OPENING PORTHOLES W/ SCREEN
	PORT AND STARBOARD CABIN
1.	TWIN SINGLE BERTHS W/MATTRESSES AND DRAWERS UNDER NEATH
2.	HANGING LOCKERS WITH LIGHTS
3.	CEILING LIGHTS AND READING LIGHTS

4.	STEREO CD PLAYER W/SPEAKERS
5.	DRESSING TABLE WITH VANITY SWING OUT SEAT
6.	POWER SOCKETS
7.	INTERCOM SYSTEM
8.	INDEPENDENT PRIVATE HEAD FOR BOTH CABINS
9.	MEDICINE CABINET W/ MIRROR DOOR
10.	GRANITE/MARBLE/CORIAN COUNTER TOP W/ BASIN
11.	HOT AND COLD WATER MIXER FAUCET
12.	SEALAND VACUFLUSH TOILET AND TOILET PAPER HOLDER
13.	STALL SHOWER ROOM W/DOOR AND TEAK GRATE
14.	CHROME SHOWER FITTING AND TOWEL RING/BAR
15.	EXHAUST BLOWER
16.	OPENING PORTHOLES
	MID MASTER STATEROOM
1.	KING SIZE BERTH W/ MATTRESS AND UPHOLSTERED/LEATHER BED HEAD
2.	COUCH IN LEATHER/FABRIC
3.	DRESSING TABLE WITH FOLDING MIRROR WITH VANITY SWING OUT SEAT
4.	WALK-IN CLOSET WITH LIGHTS
5.	CEILING LIGHTS AND READING LIGHTS
6.	LOCKERS AND DRAWERS
7.	STEREO CD PLAYER W/ SPEAKERS
8.	MIRROR ON BACK WALLS
9.	POWER SOCKETS
10.	TELEPHONE/INTERCOM SYSTEM
11.	4 OPENING PORTHOLES
12.	INDEPENDENT PRIVATE HEAD
13.	MEDICINE CABINET W/ MIRROR DOOR
14.	SEALAND VACUFLUSH TOILET AND TOILET PAPER HOLDER
15.	JACUZZI BATH TUB W/ FAUCET & SHOWER FITTINGS
16.	EXHAUST BLOWER
17.	GRANITE OR CORIAN COUNTER TOP W/BASIN
	AFT VIP STATEROOM
1.	KING SIZE BERTH W/ MATTRESS AND UPHOLSTERED/LEATHER BED HEAD
2.	MIRROR ON BACK WALLS
3.	DRESSING TABLE WITH FOLDING MIRROR WITH VANITY SWING OUT SEAT
4.	WALK-IN CLOSET WITH LIGHTS
5.	CEILING LIGHTS AND READING LIGHTS
6.	LOCKERS AND DRAWERS
7.	RADIO AND CD PLAYER W/SPEAKERS
8.	CENTER SKY MIRROR
9.	CONCEALED ESCAPE HATCH IN SKY MIRROR TO AFT DECK
10.	POWER SOCKETS
11.	PANASONIC TELEPHONE/INTERCOM SYSTEM
12.	4 OPENING PORTHOLES
13.	INDEPENDENT PRIVATE HEAD

14.	SEALAND VACUFLUSH TOILET
15.	STALL SHOWER ROOM W/ FAUCET & SHOWER FITTINGS
16.	GRANITE OR CORIAN COUNTER TOP W/BASIN
17.	EXHAUST BLOWER
18.	CABINET W/MIRROR
19.	WASHER/DRYER UNDER THE TV CABINET W/DOOR
20.	ENGINE ROOM ACCESS DOOR WITH SOUND INSULATION
	<u>ENGINES AND STERNGEAR</u>
1.	WATERTIGHT ENGINE ROOM BULKHEADS
2.	ACCESS THROUGH SALOON FLOOR HATCHS
3.	WATERTIGHT DOOR TO ENGINE ROOM
4.	LEADED FOAM WITH ALUMINUM PLATES INSULATION
5.	HIGH VOLUME ENGINE AIR INTAKES
6.	ENGINE ROOM EXTRACTOR FANS
7.	ENGINE EXHAUST SILENCERS AND WATER COOLED EXHAUST
8.	STAINLESS STEEL POLISHED ENGINE BEDS INTEGRALLY BONDED
9.	ENGINE SOFT MOUNTED
10.	ENGINE ROOM DC LIGHTS AND AIRTIGHT AC LIGHTS
11.	WATER COOLED ENGINE EXHAUST UNDER WATER AND BY -PASS OUTLETS ABOVE WATER AT TRANSOM
12.	CATHODIC PROTECTION FOR STERNGEAR
13.	STERNGEAR, ENGINES, FUEL TANKS, FILLERS, ETC ALL ELECTRICALLY BONDED
14.	ENGINE DRIVEN AND AUTOMATIC ELECTRIC BILGE PUMPS
15.	ELECTRONIC ENGINE CONTROLS
16.	NIBRAL PROPELLERS
17.	ARMCO AQUAMET SHAFTS
18.	BRONZE STRUTS
19.	S.S. RUDDERS W/ S.S. POSTS
20.	FIRE EXTINGUISHING SYSTEM
21.	FITTINGS AND MOUNTS FOR GEN SETS AND ACCE SSORIES
	<u>MECHANICAL & MISCELLANOUS</u>
1.	ALUMINIUM FUEL TANKS W/SEPARATE FILLERS AND VENTS
2.	S.S. WATER TANK W/FILLER AND SHORE WATER CONNECTOR
3.	WATER LEVER GAUGE
4.	RACOR FUEL/WATER FILTERS
5.	WATER HEATER 20 GALLONS CONNECTED TO GEN SET COOLING SYSTEM
6.	AUTOMATIC WATER PRESSURE PUMP FOR HOT AND COLD WATER
7.	OIL CHANGE SYSTEM
8.	GREY WATER TANK W/PUMP
9.	HOLDING TANK W/MACERATOR PUMP AND SEA/DOCKSIDE DISCHARGE
10.	HOLDING TANK LEVER GAUGE
11.	MANUAL BILGE PUMP
12.	4 X HIGH CAPACITY ELECTRICAL BILGE PUMPS W/AUTOMATIC FLOAT SWITCHES
13.	EXHAUST BLOWERS W/TUBING

14.	SEA WATER STRAINERS
15.	ALL THR-HULL W/SEACOCKS
16.	COLOR CODED PLUMBING SYSTEM
	<u>ELECTRICAL APPLIANCES</u>
1.	ALL DC & AC CIRCUITS PROTECTED BY CIRCUIT BREAKERS
2.	COLOR CODED WIRING SYSTEMS
(A)	<u>DC 12V SYSTEM</u>
1.	12V FOR NAVIGATION AND RADIO CIRCUITS
2.	1 x 100 A.H. BATTERY FOR GENERATOR STARTING AND CHARGED BY GEN SET OR BATTERY CHARGER
3.	1 x 25AMP BATTERY CHARGER FOR BATTERY BANK
(B)	<u>DC 24V SYSTEM</u>
1.	2 x 200 A.H. HEAVY DUTY BATTERIES FOR ENGINE STARTING AND CHARGED BY ENGINE OR BATTERY CHARGER
2.	2 x 200 A.H. HEAVY DUTY BATTERIES FOR DOMESTIC SERVICE AND CHARGED BY ENGINE OR BATTERY CHARGER
3.	1 x 100 A.H. BATTERY FOR WINDLASS & BOW THRUSTER
4.	1 x 80 AMP 24V BATTERY CHARGER
5.	BATTERY MASTER SWITCH AT MAIN SWITCH PANEL
6.	DC LIGHTING THROUGHOUT
(C)	<u>AC 120V SYSTEM(240V AVAILABLE)</u>
2.	SHORE POWER SUPPLY
3.	GENERATOR/SHORE SUPPORT CHANGE OVER SWITCHES
4.	POLARITY CHECK SYSTEM
5.	AC SOCKETS THROUGHOUT (GFI SOCKETS AT HEADS AND GALLEY)
6.	EARTH LEAKAGE SAFETY TRIP
7.	AC INSERT TUBE LIGHTS

Since we strive for continuous improvement, this specification list is subject to change without notice.

LOA	LWL	BEAM	DRAFT	OWNER
70'-0"	57'-1"	18'-1"	3'-7"(BL)	

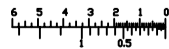
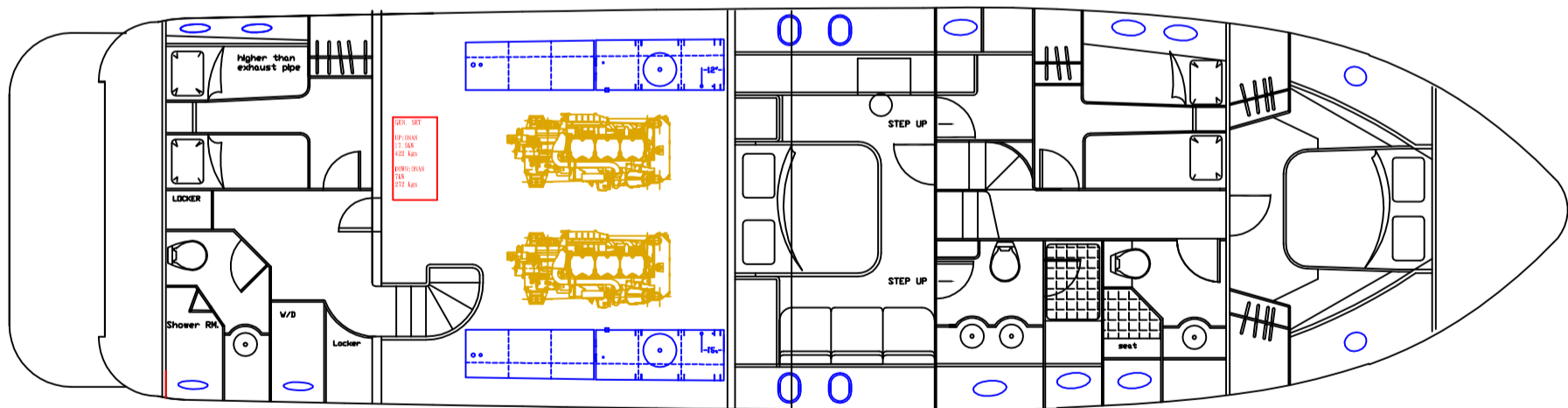
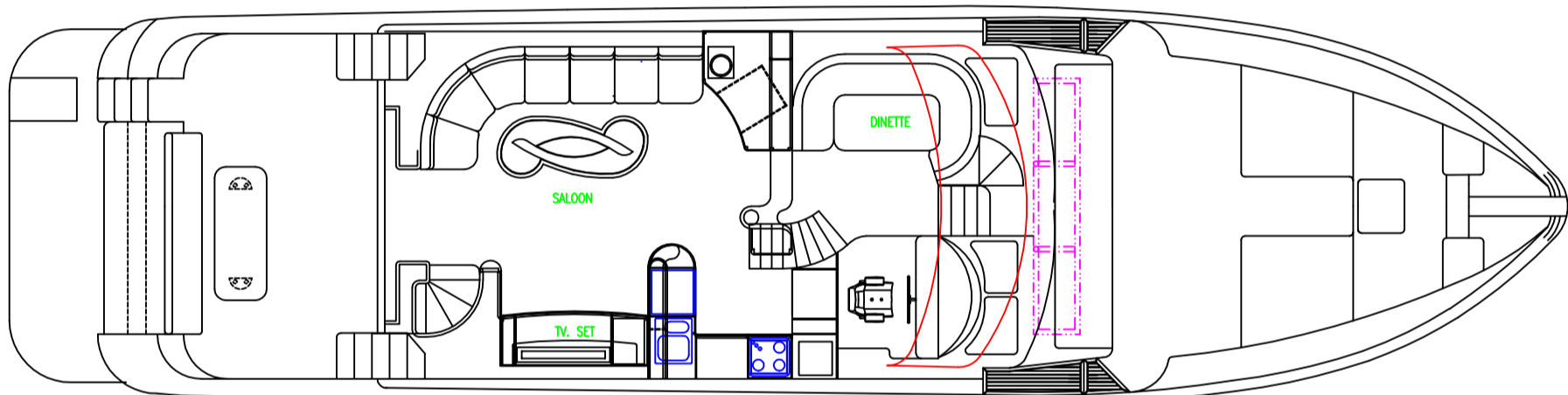
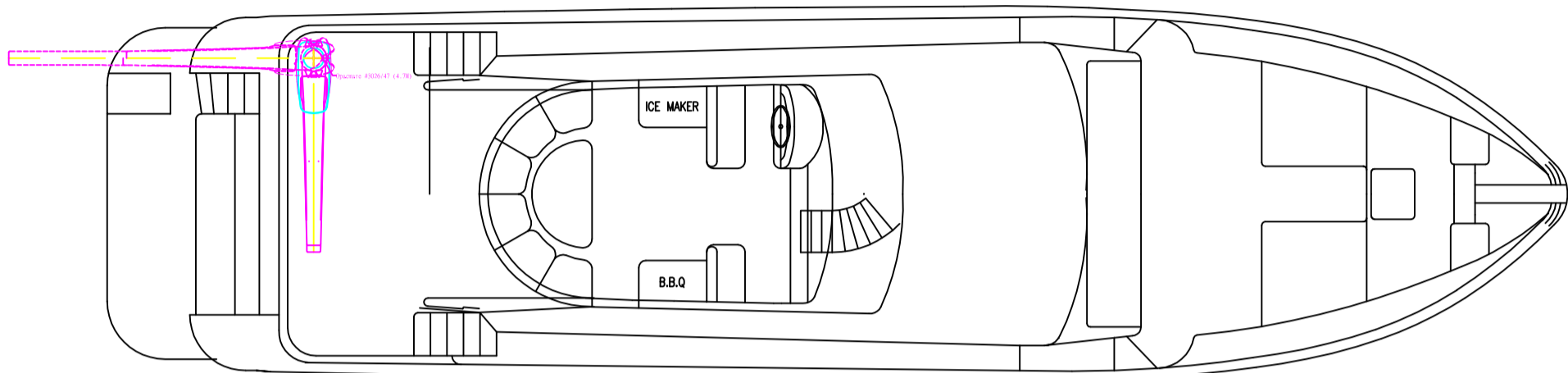

<i>Dyna 70 Laguna</i> <i>General Layout</i>	BOAT NO.: D70-026		DW'G NO: D70026G001A		
	SCALE	DATE	DW'N BY	DS' BY	VERIFY
	1/4":1'	2007/07/25	Linjs		

LOA	LWL	BEAM	DRAFT	OWNER
70'	57'-2"	18'-1"	3'-7"	

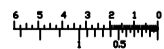
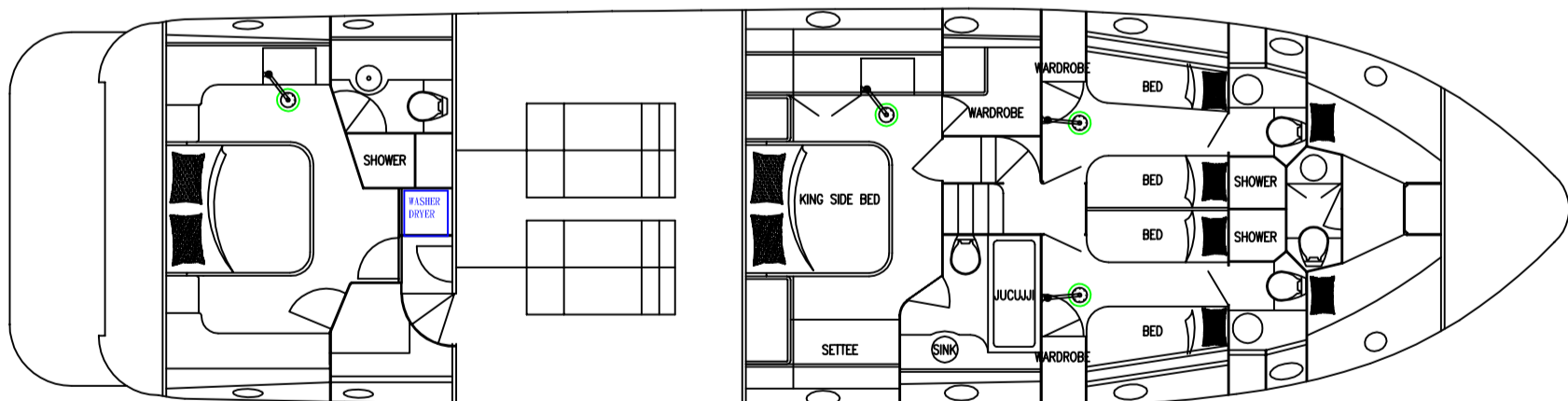
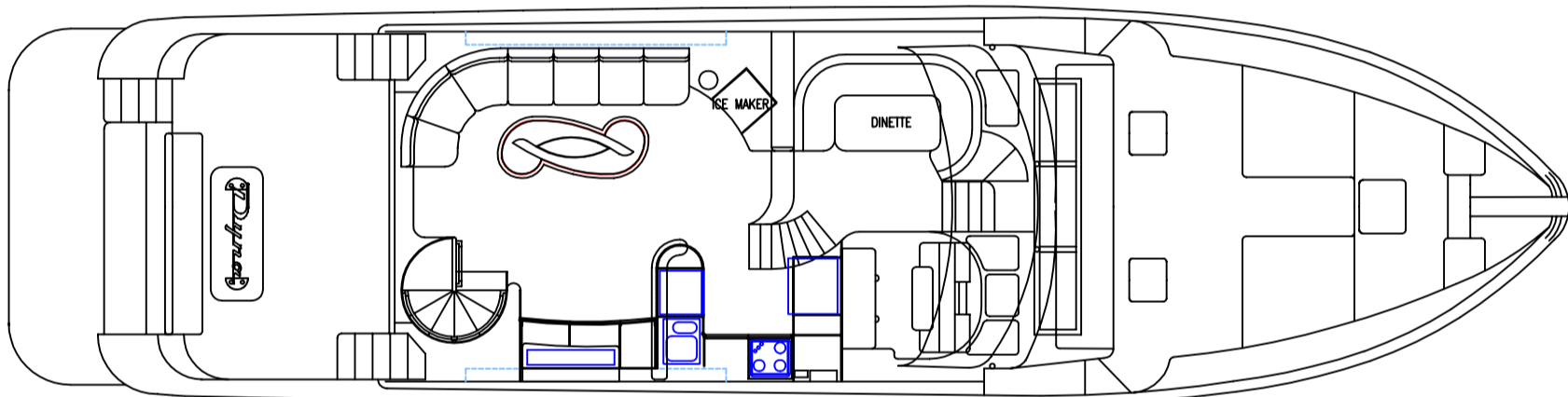
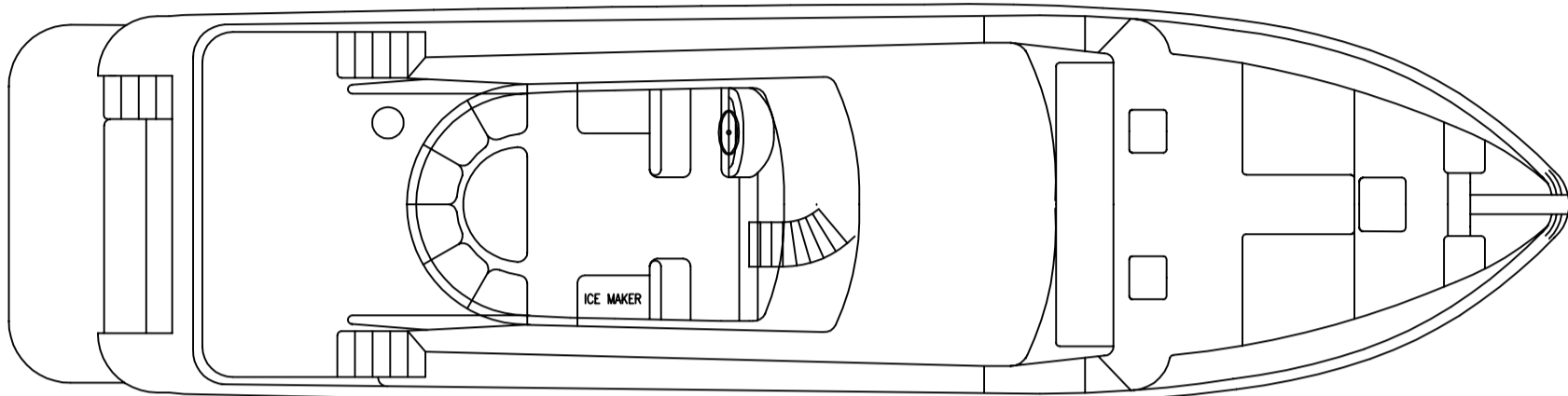

Dyna 70 Laugna <i>General Layout</i>	BOAT NO. 70028	DW'G NO D70028G001A	SCALE 1/8":1'	DATE 2005/03/07	DW'N BY Linjs	DS' BY Terry	VERIFY
--	-------------------	------------------------	------------------	--------------------	------------------	-----------------	--------