



## 2008 DYNA 55' Standard Specification List

ITEM	GENERAL SPECIFICATION
1.	LENGTH OVERALL 16.61M (54'-6")
2.	BEAM 4.72M (15'-6")
3.	DRAFT UNDER PROPELLERS 1.27M (4'-2")
4.	HEIGHT ABOVE WATERLINE TO TOP OF MAST 4.72M (15'-6")
5.	FUEL CAPACITY 2274L (600 US GALS)
6.	FRESH WATER CAPACITY 758L (200 US GALS)
7.	DRY DISPLACEMENT 19000KGS (42530LBS)
8.	SLEEPING ACCOMODATION 6~10P
9.	Engine Options: CAT-C9(510HP)/C12(705HP) VOLVO-D9(575HP) /D12(715HP,770HP) / IPS600(435HP) YANMAR-720HP
10.	ONAN 11KW/50HZ GENERATOR (13.5KW/60HZ)
11.	MARINE AIR AIRCONDITIONER W/REVERSE CYCLE HOT & COLD TOTAL 56000BTU's
	<b>HULL FORM AND CONSTRUCTION</b>
1.	DEEP-V HULL BOTTOM
2.	ALL FIBERGLASS THROUGHOUT THE BOAT LAID UP BY HAND
3.	FOAM CORE CONSTRUCTION ABOVE WATER LINE
4.	SOLID FIBERGLASS CONSTRUCTION BELOW WATER LINE
5.	EXTENSIVE NETWORK OF TRANSVERSE AND LONGITUDINAL STRINGERS GLASSED IN THE HULL BOTTOM
6.	THE INTERIOR OF HULL BOTTOM IS PAINTED OUT IN GELCOAT
7.	DECK SIDES ARE FOAM CORE CONSTRUCTION
8.	CABIN TOPS ARE Balsa CORE CONSTRUCTION
9.	THE HULL AND DECK ARE BOLTED AND FRP BONDED TOGETHER
10.	MOULDED NON-SLIP DECK SURFACE
11.	ANTIFOULING
12.	LAMINATION WITH VINYLESTER RESIN TO PREVENT OSMOSIS
	<b>DECK FITTING</b>
1.	REVERSIBLE ELECTRIC LOFRANS WINDLASS WITH REMOTE CONTROL FROM BOTH HELM AND DIRECT CONTROL ON THE FORE DECK
2.	S/S ANCHOR 45LBS & GALVANIZED CHAIN 50M
3.	FLAG POLE SOCKET
4.	STAINLESS STEEL BOW ROLLER AND BOW SPIRIT
5.	STAINLESS STEEL STANCHION & HANDRAIL
6.	STAINLESS STEEL CHAINWAY
7.	12" 316 STAINLESS STEEL MOORING CLEAT (4)
8.	10" 316 STAINLESS STEEL SPRING CLEAT (4)
9.	NON-SKIP SURFACE ON DECKS
10.	HEAVY DUTY RUBBER W/ S.S. RUBRAIL
11.	WINDOWS IN TEMPERED GLASS DIRECTLY MOUNTED ON FRP
12.	FORE DECK ESCAPE HATCH
13.	FWD DECK SUN LOUNGE PADS
14.	WATER AND FUEL FILLERS
15.	STAINLESS STEEL OPENING PORTHOLES WITH SCREENS
16.	SELF DRAINING

	<b>COCKPIT</b>
1.	ACCESS HATCH W/ LADDER TO LAZARETTE
2.	STAINLESS STEEL FRAME SLIDING DOOR TO SALO ON
3.	FRP STAIRS TO FLYBRIDGE
4.	TEAK LAID COCKPIT AND SWIMMING PLATFORM
5.	AFT DECK FRP SEAT WITH CUSHION AND STORAGE UNDERNEATH
6.	LOCKERS FOR MOORING LINES
7.	SHORE POWER INLET CONNECTION
8.	AFT DECK WASH DOWN (FRESH WATER)
9.	SELF DRAINING
10.	COCKPIT HALOGEN LIGHTING WITH REMOTE CONTROL
11.	WATERPROOF SOUND MARINE STEREO SPEAKERS
12.	TRANSOM DOOR TO SWIMMING PLATFORM
13.	TRANSOM SHOWER (HOT & COLD)
14.	CONCEALED STAINLESS STEEL SWIMMING LADDER
	<b>FLYBRIDGE AND SECOND HELM POSITION</b>
1.	STAINLESS STEEL HANDRAILS WITH ACRYLIC WINDSHIELD
2.	FLYBRIDGE FRP INSTRUMENTS BOARD WITH BURL PANEL AND ACRYLIC COVER
3.	HYDRAULIC STEERING SYSTEM AND STEERING WHEEL
4.	MORSE KE-4 ELECTRONIC ENGINE CONTROLS
5.	START/STOP ENGINES KEYS
6.	ENGINE RPM GAUGES
7.	ENGINE COOLING WATER TEMPERATURE GAUGES
8.	ENGINE OIL PRESSURE GAUGES
9.	AUDIBLE AND VISUAL ENGINE ALARM
10.	BILGE PUMP AUDIBLE ALARM
11.	REMOTE WINDLASS CONTROL
12.	SEARCHLIGHT WITH REMOTE CONTROL
13.	COMPASS AND MARINE HORN
14.	RUDDER AND TRIM TAB INDICATORS
15.	INTERCOM
16.	HELM SEAT
17.	WET BAR W/ CABINET FOR ICE MAKER OR STORAGE
18.	CURVATURE SETTEE WITH CUSHION AND FRP TABLE
19.	ACCESS HATCH FROM COCKPIT BY FRP STAIRSWAY
20.	RADAR ARCH
21.	INTERNATIONAL NAVIGATION LIGHTS
22.	WATERPROOF STEREO SPEAKERS UNDER THE RADAR ARCH
23.	FLAG POLE SOCKET
24.	FRP NONSKID FLOOR
25.	SELF DRAINING
	<b>INTERIOR</b>
1.	PLYWOOD CABIN SOLE THROUGHOUT WITH CARPET ( EXCEPT GALLEY )
2.	CHOICE OF WOOD VENEER ON SIDES AND BURL WOOD COUNTER TOP (STANDARD TEAK, MAPLE OR CHERRY VENEER AND CAMPHOR BURL TOP)
3.	CHOICE OF UPHOLSTERY FABRICS FOR CURTAINS , DRAPES AND BED MATTRESS COVERS IN SALON AND ALL CABINS (OPTIONAL PILLOW S AND BEDSPREADS)
4.	VINYL HEAD LINERS AND LEATHER SEATINGS
5.	TEAK LAID GALLEY FLOOR
6.	JOINERY AND WOODWORK IS SUPERBLY FINISHED IN HIGH GLOSS
7.	STANDARD TWO CABIN/THREE CABIN WITH GALLEY DOWN LAYOUT
8.	VIMAR SWITCHES AND OUTLETS
9.	GROHE SHOWER FITTING
10.	GFI OUTLET IN CABIN HEADS AND GALLEY AREA

	<b>UPPER SALON AND MAIN HELM POSITION</b>
1.	LOWER HELM STATION W/LEATHER HELM SEAT
2.	NAVIGATION SWITCHES PANEL
3.	REPEAT ENGINE CONTROLS AND INSTRUMENTS
4.	REPEAT STEERING SYSTEM WITH STEERING WHEEL
5.	WINDLASS CONTROL
6.	SEARCHLIGHT CONTROL
7.	FUEL GAUGES
8.	RUDDER INDICATOR
9.	TRIM TAB INDICATORS
10.	COMPASS AND MARINE HORN SWITCH
11.	INTERCOM
12.	CURVATURE DINETTE LEATHER SETTEE W/ STORAGE BENEATH AND TABLE
13.	LOCKERS WITH STORAGE
14.	BAR CABINET
15.	ACCESS STAIRS TO LOWER DECK
16.	CEILING HALOGEN LIGHTS
17.	SWITCHES AND POWER SOCKETS
	<b>LOWER SALOON</b>
1.	CURVATURE LEATHER SETTEE W/COFFEE TABLE
2.	ENTERTAINMENT CABINET W/ TV PRE-WIRING
3.	STEREO SONY CD PLAYER WITH 2 x SOUND MARINE SPEAKERS
4.	CABINETS OR DRAWERS
5.	SWITCHES, POWER SOCKETS, VOLUME & AIRCONDITIONG CONTROL
6.	CANTALUPI CEILING HALOGEN LIGHTS
7.	STAINLESS STEEL FRAMED SLIDING DOOR TO AFT DECK
8.	CARPET FLOORING W/ ACCESS TO ENGINE ROOM
9.	CONCEALED ICEMAKER WITH DOOR
10.	CONCEALED ELECTRICAL PANELS WITH MAIN SWITCH, AC & DC BREAKES
	<b>FWD VIP CABIN</b>
1.	QUEEN SIZE BERTH WITH STORAGE UNDER
2.	TWIN DRESSING TABLES AND DRAWERS
3.	HANGING LOCKER WITH LIGHT
4.	ROUND ESCAPE HATCH TO FOREDECK
5.	MIRROR BACK WALLS WITH TWO READING LIGHTS
6.	HALOGEN CEILING LIGHTINGS, SWITCHES & POWER SOCKETS
7.	2 SPEAKERS CONNECTED FROM SALOON STEREO CD
8.	OPENING PORTHOLES (4)
9.	INTERCOM AND TV PREWIRING
10.	VOLUME & AIRCONDITIONING CONTROL
11.	PRIVATE ACCESS TO HEAD
	<b>FWD VIP HEAD</b>
1.	ACCESSIBLE FROM FWD CABIN AND CORRIDOR
2.	MEDICINE CABINET W/MIRROR
3.	VACUFLUSH MARINE TOILET W/HOLDING TANK FOR SEA/DOCKSIDE DISCHARGE
4.	WASH BASIN WITH HOT AND COLD WATER MIXER FAUCET
5.	GRANITE COUNTER TOP
6.	HOT AND COLD SHOWER WITH AUTOMATIC PUMP OUT
7.	INDEPENDENT STALL SHOWER ROOM WITH DOOR
8.	CHROME SHOWER FITTINGS AND TEAK GRATES IN SHOWER ROOM
9.	TOWEL HOLDER
10.	TOILET ROLL HOLDER

11.	OPENING PORTHOLE
12.	EXTRACTOR FAN
	<b><i>GALLEY DOWN (OPTIONAL GALLEY UP)</i></b>
1.	GRANITE COUNTER TOP
2.	TEAK & HOLLY FLOOR
3.	STAINLESS STEEL DOUBLE SINK WITH CHOPPING BOARD
4.	KENYON CERAMIC 3 RING COOKTOP
5.	MICROWAVE
6.	NORCOLD OR ULINE REFRIGERATOR
7.	DISH CABINETS AND DRAWERS
8.	TRASH BIN
9.	EXHAUST BLOWER ABOVE COOKER
10	WATER GAUGE
	<b><i>MID MASTER CABIN (OR TWO GUEST STATEROOMS)</i></b>
1.	KING SIZE BERTH
2.	HANGING LOCKER W/LIGHTS
3.	NIGHTSTANDS W/DRAWER UNDER
4.	READING LIGHTS
5.	HALOGEN CEILING LIGHTINGS
6.	INTERCOM
7.	CD PLAYER WITH 2 STEREO SPEAKERS
8.	OPENING PORTHOLES
9.	SWITCHES, POWER SOCKETS, VOLUME & AIRCONDITIONG CONTROL
10.	MIRRORS ON BACK WALL
11.	DIRECT ACCESS TO MASTER HEAD
12.	PREWIRING FOR TV
	<b><i>MASTER HEAD</i></b>
1.	DIRECT ACCESS FROM MASTER CABIN
2.	MEDICINE CABINET W/MIRROR
3.	VACUFLUSH MARINE TOILET W/HOLDING TANK FOR SEA/DOCKSIDE DISCHARGE
4.	WASH BASIN WITH HOT AND COLD WATER MIXER FAUCET
5.	GRANITE COUNTERTOP
6.	HOT AND COLD SHOWER WITH AUTOMATIC PUMP OUT
7.	INDEPENDENT STALL SHOWER ROOM WITH DOOR
8.	CHROME SHOWER FITTINGS
9.	TOWEL HOLDER
10.	TOILET ROLL HOLDER
11.	OPENING PORTHOLE
12.	EXTRACTOR FAN
**	<b>STANDARD 2 or 3 CABIN + GALLEY DOWN SEE LAYOUT "B" OR "C" OPTIONAL 3 CABIN LAYOUT + GALLEY UP</b>
	<b><i>ENGINE COMPARTMENT AND LAZARETTE</i></b>
1.	ACCESS HATCH WITH S.S. LADDER FROM COCKPIT TO LAZARETTE
2.	ENGINE ROOM ACCESSIBLE FROM THE SALOON
3.	HIGH VOLUME AIR INTAKES
4.	WATER COOLED ENGINE EXHAUST UNDER WATER AND BY-PASS OUTLETS ABOVE WATER AT TRANSOM
5.	EXHAUST BLOWERS W/TUBING
6.	RACOR FUEL/WATER FILTERS
7.	LEAD FOAM ENGINE ROOM SOUND INSULATION
8.	ENGINE ROOM LIGHTING

9.	ALUMINIUM FUEL TANKS W/SEPARATE FILLERS AND VENTS
10.	HIGH CAPACITY ELECTRICAL BILGE PUMPS W/FLOAT SWITCHES (3)
11.	ENGINE ROOM FIRE EXTINGUISHING SYSTEM WITH AUTOMATIC ENGINE SHUT DOWN
12.	ARMCO AQUAMET SHAFTS AND DRIPLESS SHAFT SEALS
13.	4 BLADE MN-BZ PROPELLERS
14.	BRONZE V STRUTS
15.	STAINLESS STEEL RUDDERS WITH STAINLESS STEEL POSTS
16.	AIR-CONDITIONING COMPRESSING UNITS
17.	MAIN GENERATOR IN LAZARETTE
18.	FRP NONSKID FLOORING
19.	COLOR CODED PLUMBING SYSTEM
20.	WATERTANK IN LAZARETTE AND ACCESS DOOR TO ENGINE ROOM
21.	WATER HEATER IN LAZARETTE
22.	FRESH WATER FAUCET
	<b>ELECTRICAL SYSTEM</b>
<b>(A)</b>	<b><u>DC 12V SYSTEM</u></b>
1.	12V FOR NAVIGATING AND RADIO CIRCUITS
2.	1 x 100 A.H. BATTERY FOR GENERATOR STARTING AND CHARGED BY GEN SET OR BATTERY CHARGER
3.	1 x 25AMP BATTERY CHARGER FOR BATTERY BANK
<b>(B)</b>	<b><u>DC 24V SYSTEM</u></b>
1.	TWO 200 AH BATTERIES WIRED IN PARALLEL SUPPLY THE DOMESTIC SERVICE AND ACCEPT CHARGE FROM BATTERY CHARGER OR ENGINE
2.	TWO 200 AH BATTERIES START BOTH ENGINE AND CHARGED BY ENGINE OR BATTERY CHARGER
3.	DC LIGHTING THROUGHOUT
4.	BATTERY MASTER SWITCH AT MAIN SWITCH PANEL
5.	CIRCUIT BREAKERS ON ALL CIRCUITS
6.	BONDING SYSTEM W/ZINC PLATES
<b>(B)</b>	<b><u>120V SYSTEM (240V AVAILABLE)</u></b>
1.	SHORE POWER INLET AT COCKPIT
2.	MASTER DC AND AC CIRCUIT BREAKER PANELS IN THE SALOON
3.	AC CIRCUIT BREAKERS ON ALL CIRCUITS
4.	SPARE CIRCUIT BREAKERS ARE PROVIDED FOR OPTIONAL EQUIPMENT
5.	AC OUTLETS THROUGHOUT
6.	COLOR CODED WIRING SYSTEM
	<b>WATER SYSTEM</b>
1.	STAINLESS STEEL WATER TANK W/FILLER AND SHORE WATER CONNECTION
2.	20 GALS WATER HEATER W/HEAT EXCHANGER
3.	AUTOMATIC WATER PRESSURE PUMP FOR HOT AND COLD WATER
4.	HOT AND COLD WATER SYSTEM TO ALL HEADS/GALLEY/COCKPIT
5.	COLD WATER SYSTEM TO ENGINE ROOM AND FLYBRIDGE
6.	ALL THRU-HULL WITH SEACOCKS
7.	ANCHOR CHAIN WASHDOWN SYSTEM (SEA WATER)
8.	AFT DECK FRESH WATER WASH DOWN
9.	SEA WATER STRAINERS
10.	SUMP TANK AND SHOWER PUMP

*Since we continuously strive for improvements, this specification list is subject to change without notice.*

LOA	LWL	BEAM	DRAFT	OWNER
54'-6"	47'	15'-6"	2'-5"	

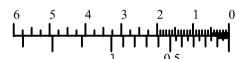
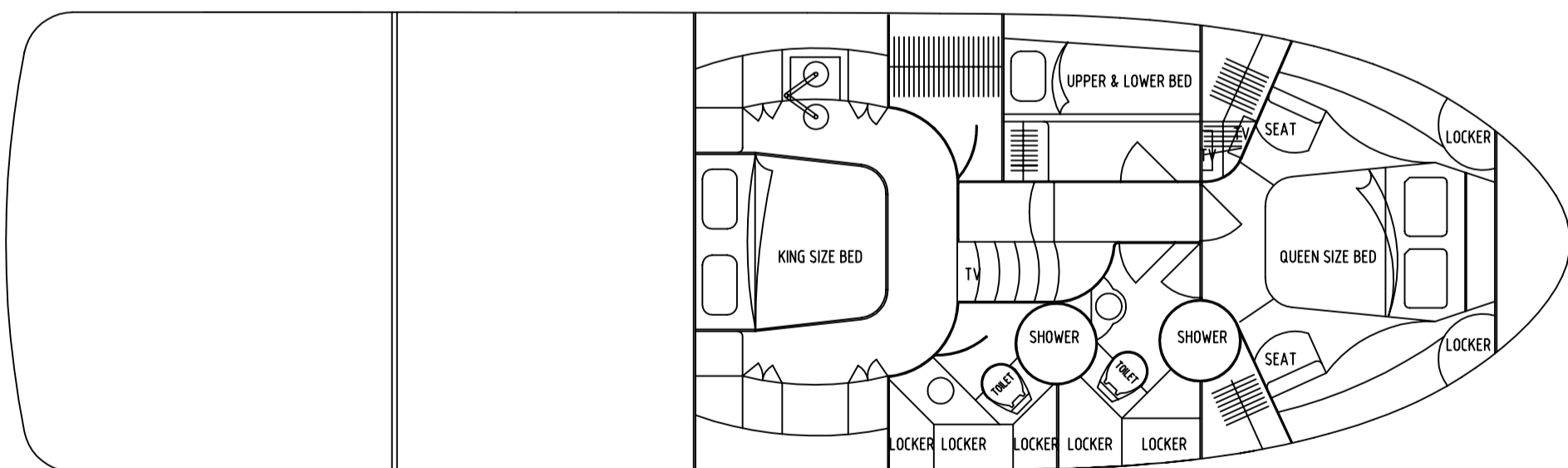
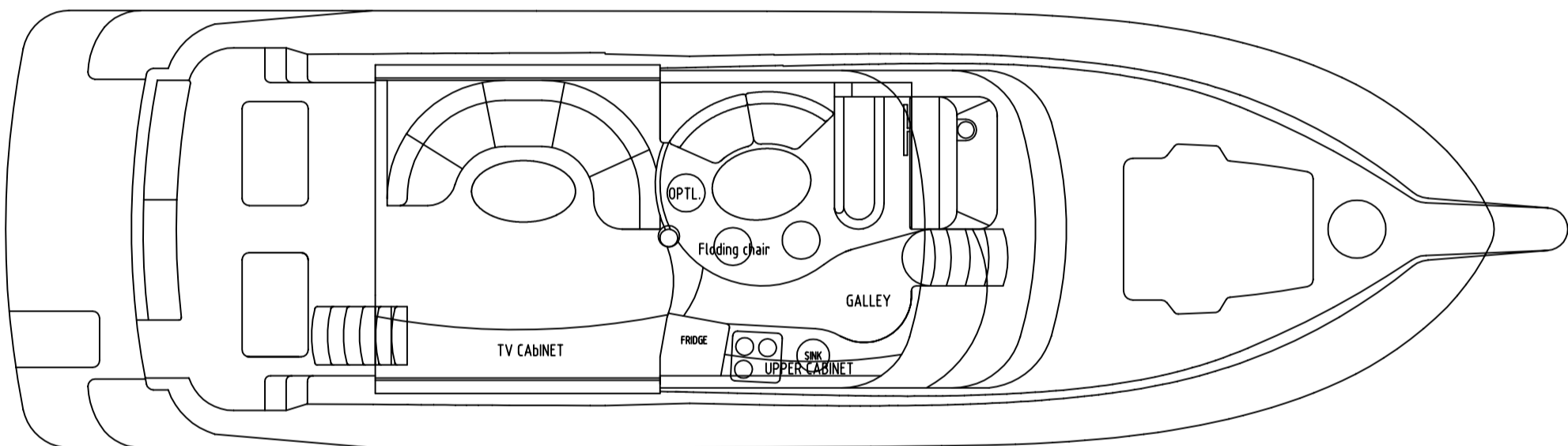
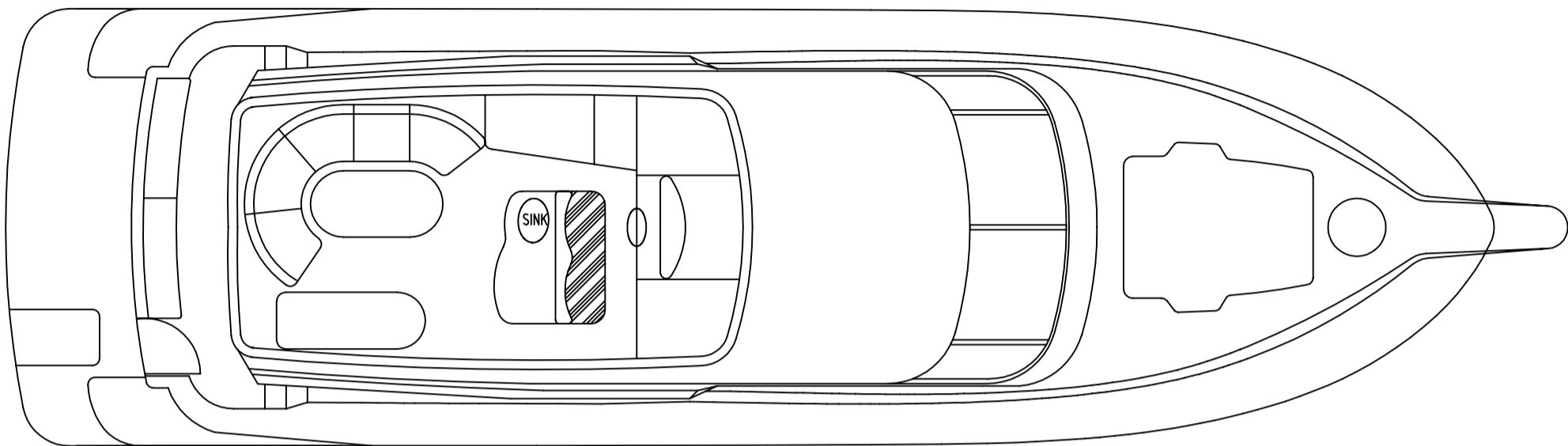

<i>Dyna 55' Euro-style</i>	BOAT NO.	DW'G NO	SCALE	DATE	DW'N BY	DS' BY	VERIFY
General Layout	Type 2007	D55XXXG01-A	3/16":1'	2007/06/06	Eddie		

LOA	LWL	BEAM	DRAFT	OWNER
54'-6"	47'	15'-6"	2'-5"	

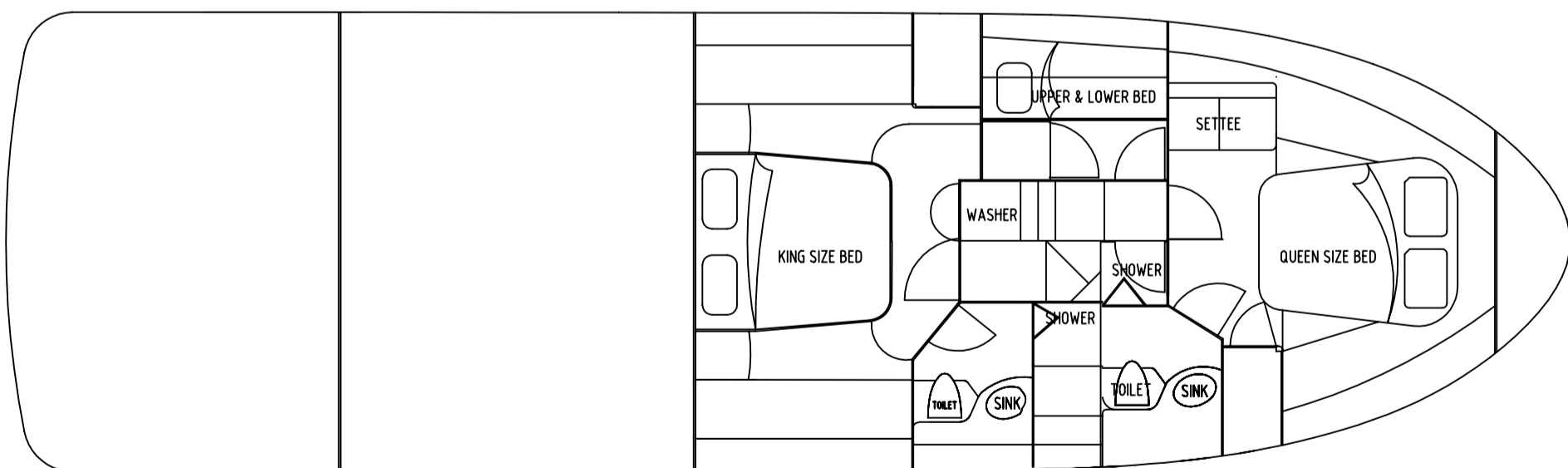
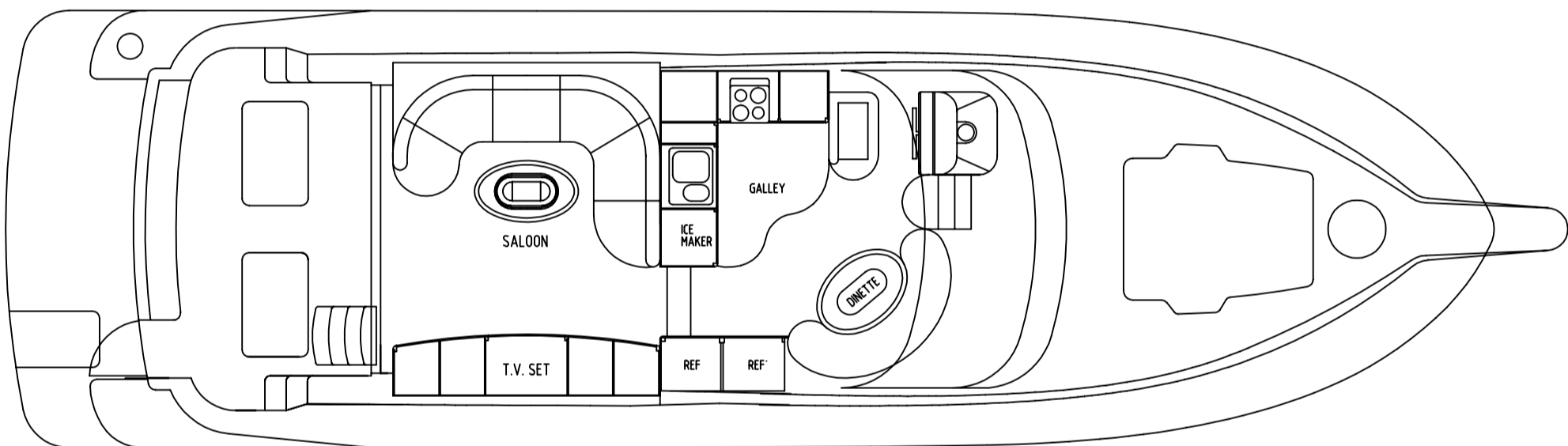
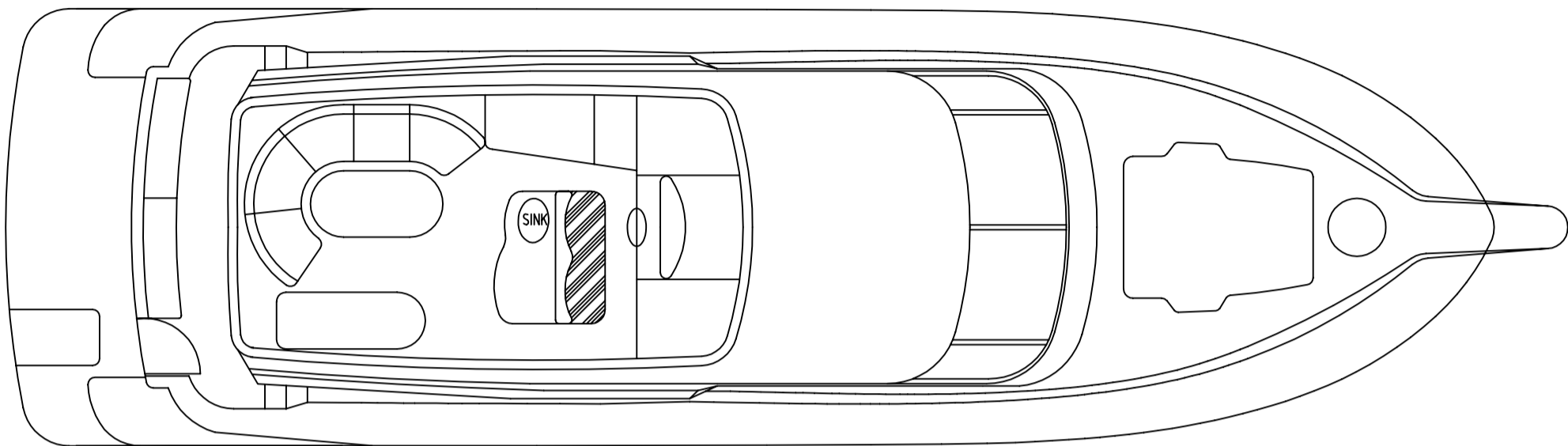

<b>Dyna 55'</b>	BOAT NO.	DW'G NO	SCALE	DATE	DW'N BY	DS' BY	VERIFY
General Layout	Type A	D55G01-A	3/16":1'	2007/06/06	Linjs		

LOA	LWL	BEAM	DRAFT	OWNER
54'-6"	47'	15'-6"	2'-5"	

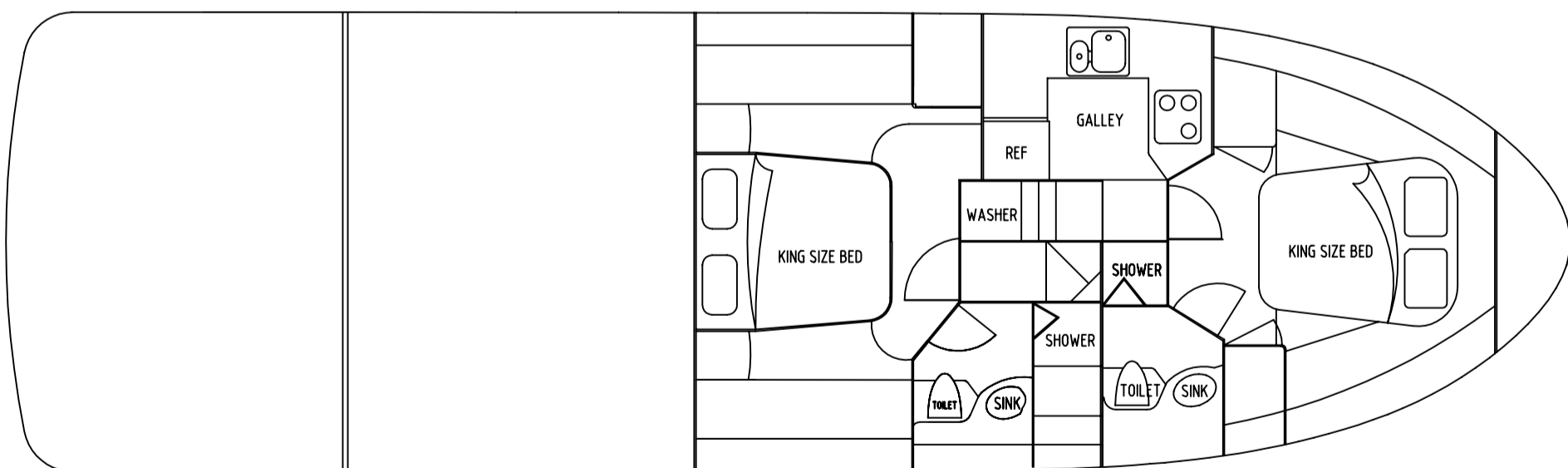
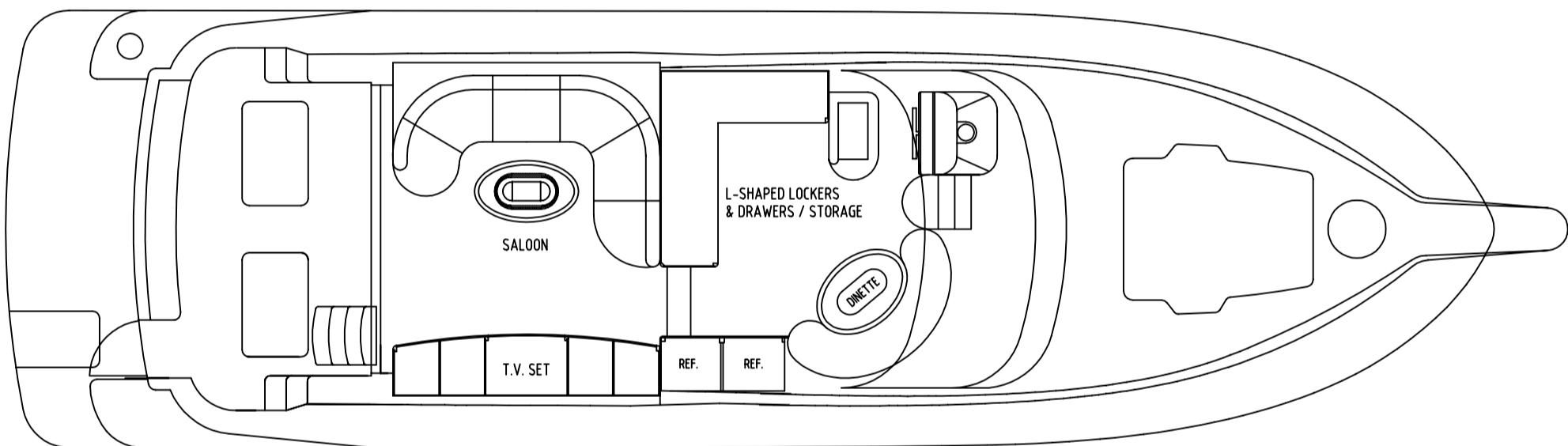
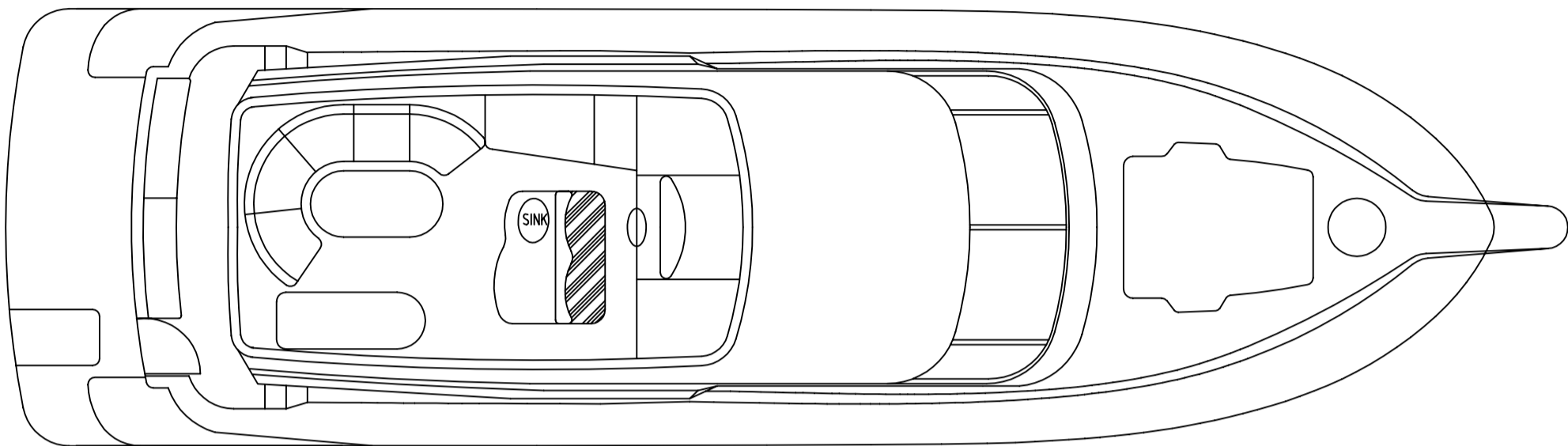

<b>Dyna 55'</b>	BOAT NO.	DW'G NO	SCALE	DATE	DW'N BY	DS' BY	VERIFY
General Layout	Type C	D55G01-C	3/16":1'	2007/06/06	Linjs		

LOA	LWL	BEAM	DRAFT	OWNER
54'-6"	47'	15'-6"	2'-5"	

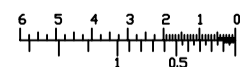
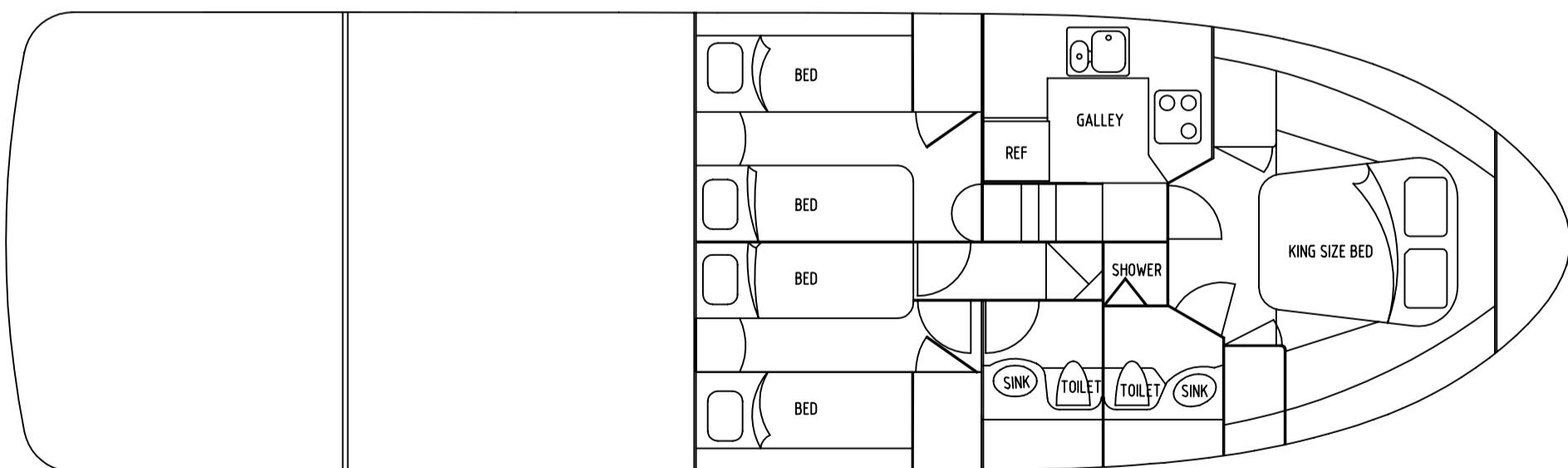
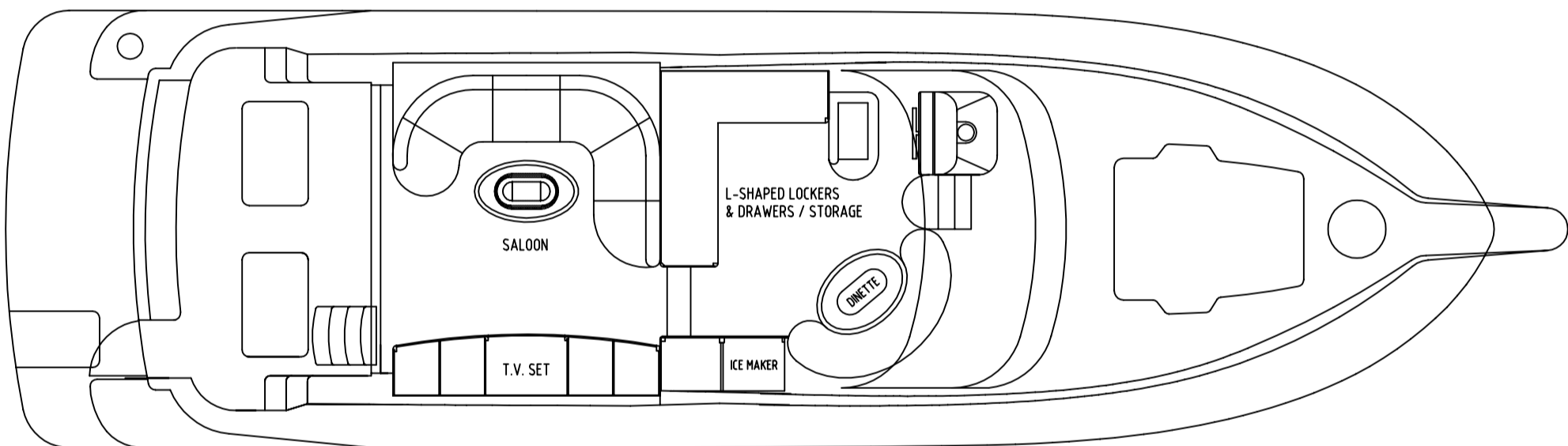
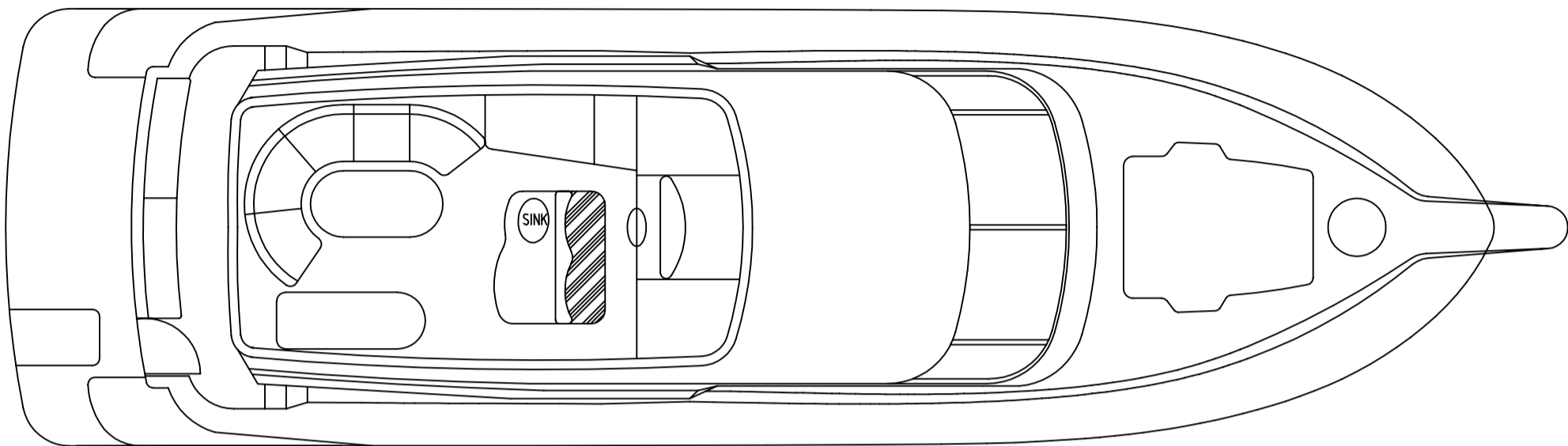

<b>Dyna 55'</b> General Layout	BOAT NO. Type B	DW'G NO D55G01-B	SCALE 3/16":1'	DATE 2007/06/06	DW'N BY Linjs	DS' BY	VERIFY
-----------------------------------	--------------------	---------------------	-------------------	--------------------	------------------	--------	--------